

Magnetic Sensor ICs

Omnipolar Detection High Performance Hall-Effect Sensor IC



● General Description

Using low power CMOS process, the AS1803OD is designed for high performance omnipolar detection hall-effect application, such as cover switch, contactless switch, solid state switch and lid close sensor etc battery operation. The hall IC integrated an on-chip hall voltage generator for magnetic sensing, a comparator that amplifiers the hall voltage, a Chopper amplifier, a Schmitt trigger to provide switching hysteresis for noise rejection, and a complementary output.

AS1803OD is designed to respond to alternating North and South poles. When the magnetic flux density (B) is larger than operate point (B_{OP}), the output will be turned on (low), the output is held until the magnetic flux density (B) is lower than release point (B_{RP}), then turn off (high).

The device is available in SOT23-3L and SIP-3L package and is rated over the -40°C to 125°C. The all packages are RoHS and Green compliant.

● Features

- Input Voltage Range : 2.2V to 5.0V
- Operation Frequency: 20kHz(min)
- Omnipolar Operation, easy to use as output
- Very high sensitivity hall sensor
- Low Power CMOS process technology
- Chopper stabilization amplifier stage
- Magnetic Sensitivity (typical)
- B_{OP}= ±18Gauss, B_{RP}= ±10Gauss
- Good RF noise immunity
- Open Drain Output
- Small Solution Size
- RoHS & Green Compliant
- SOT23-3L and SIP-3L Packages
- -40°C to +125 °C Temperature Range

● Applications

- Cover switch in clam-shell cellular phones
- Cover switch in Notebook, PC/PAD
- Contact-less switch in consumer products
- Solid State Switch
- Handheld Wireless Handset Awake Switch
- Lid close sensor for battery-powered device
- Magnet proximity sensor for reed switch replacement in low duty cycle applications
- DV, DSC, and White Goods

■ Ordering Information

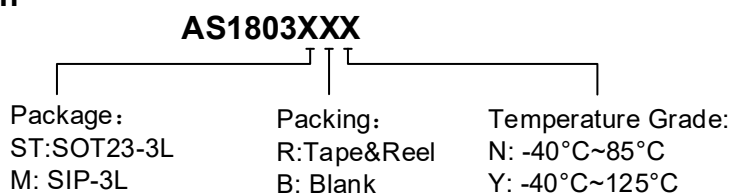

Part Number	B _{OP} (Gauss)	B _{RP} (Gauss)	Package Type	Package Qty	Temperature	Eco Plan
AS1803ODSTRN	±18Gauss	±10Gauss	SOT23-3L	7-in reel 3000pcs/reel	-40~85°C	Green
AS1803ODMBN	±18Gauss	±10Gauss	SIP-3L	1000pcs/Package	-40~85°C	Rohs
AS1803ODSTRY	±18Gauss	±10Gauss	SOT23-3L	7-in reel 3000pcs/reel	-40~125°C	Green
AS1803ODMBY	±18Gauss	±10Gauss	SIP-3L	1000pcs/Package	-40~125°C	Rohs

■ **Marking & Pin Assignment**

SOT23-3L

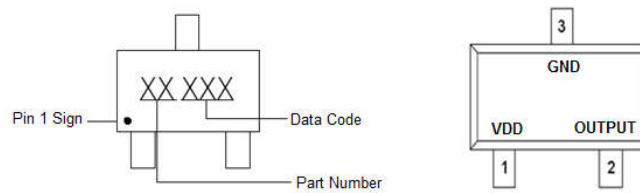

Pin Name	Pin No.	I/O	Pin Function
	SOT23-3L		
VDD	1	P	Input Power Supply
GND	3	P	Ground
OUTPUT	2	O	Output Pin

SIP-3L

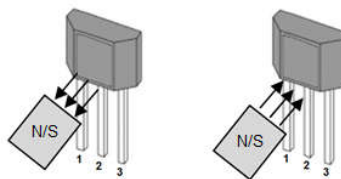

Pin Name	Pin No.	I/O	Pin Function
	SIP-3L		
VCC	1	P	Input Power Supply
GND	2	P	Ground
OUTPUT	3	O	Output Pin.

■ **Typical Application Circuit**

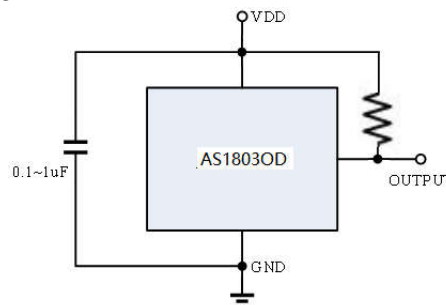

Figure 1, Typical Application Circuit of AS1803OD

■ **Block Diagram**

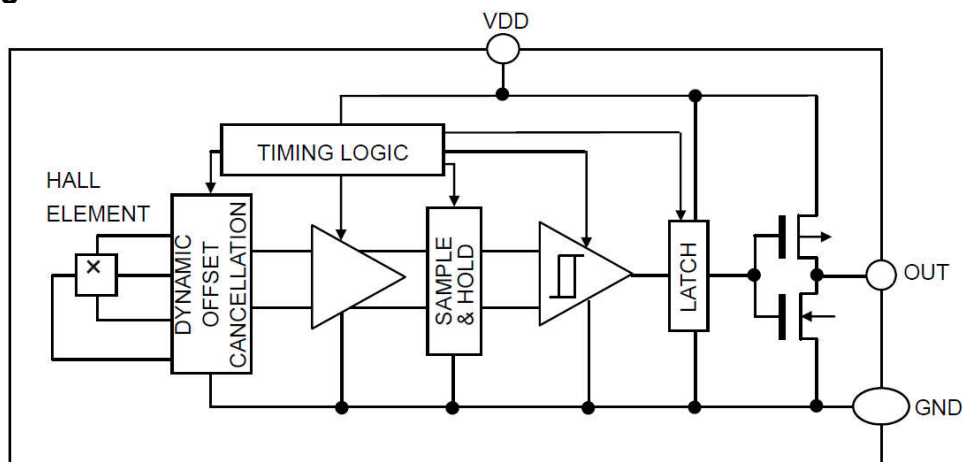

Figure 3, Block Diagram of AS1803OD

Absolute Maximum Ratings¹ (T_A=25°C, unless otherwise noted)

Parameter	Symbol	Rating	Unit	
V _{DD} Pin to GND	V _{DD}	-0.3 to 7.0	V	
Output Pin to GND	V _{OUTPUT}	-0.3 to V _{DD} +0.3	V	
Max. Continuous Output Current	I _{OUTMAX}	2.0	mA	
Magnetic Flux Density	B	Unlimited	Gauss	
Package Power Dissipation	SOT23-3L	P _D	180	mW
	SIP-3L	P _D	250	mW
ESD (HBM)	ESD	8000	V	
Storage Temperature Range	T _S	-55 to +150	°C	
Operating Junction Temperature Range	T _{OP}	-40 to +150	°C	
Maximum Soldering Temperature (at leads, 10 sec)	T _{LEAD}	300	°C	

Recommended Operating Conditions²

Parameter	Symbol	Rating	Unit
V _{DD} Pin to GND	V _{DD}	2.2 to 5.0	V
Continuous Output Current	I _{OUT}	1.0	mA
Operating Temperature Range	T _{OP}	-40 to +125	°C

Note: 1: Stresses above those listed in absolute maximum ratings may cause permanent damage to the device. Functional operation at conditions other than the operating conditions specified is not implied. Only one absolute maximum rating should be applied at any one time.

2: The device is not guaranteed to function outside of its operating conditions.

Electrical Characteristics

(T_A = -40 to +125°C unless otherwise noted. Typical values are at T_A = +25°C, V_{DD} = 3.6V)

Symbol	Parameter	Conditions	Min.	Typ.	Max.	Unit
V _{DD}	Input Voltage		2.2	3.6	5.0	V
I _{DD(AVG)}	Supply Current	Average supply current, T _A = 25°C, V _{DD} = 3.6V	-	1	-	mA
f _{BW}	Bandwidth		20	-	-	kHZ
V _{OH}	Output Off Voltage (High side)	R _{LOAD} = 10Kohms	V _{DD} - 0.3	V _{DD} - 0.1	V _{DD} + 0.3	V
V _{OL}	Output On Voltage (Low side)	I _{OUT} = -1.0mA	-0.3	0.1	+0.3	V

Magnetic Para.

B _{OPS}	Magnetic Operating Point		-	18	36	Gauss
B _{OPN}			-36	-18	-	
B _{RPS}	Magnetic Release Point		5	10	-	Gauss
B _{RPN}			-	-10	-5	
B _{HYS}	Hysteresis Window		-	8	-	Gauss

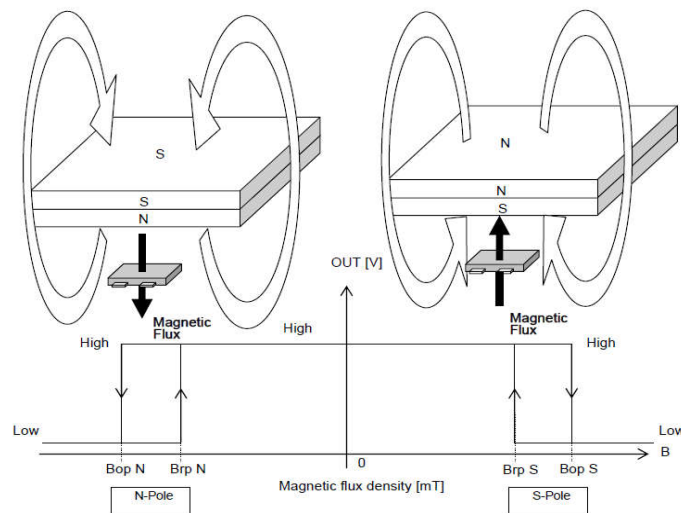

Fig 4, Magnetic Operation Characteristic of AS1803OD

■ Function Description

Chopper-Stabilized Technique

The Hall element can be considered as a resistor array similar to a Wheatstone bridge. A large portion of the offset is a result of the mismatching of these resistors. These devices use a proprietary dynamic offset cancellation technique, with an internal high-frequency clock to reduce the residual offset voltage of the Hall element that is normally caused by device over-molding, temperature dependencies, and thermal stress. The chopper-stabilizing technique cancels the mismatching of the resistor circuit by changing the direction of the current flowing through the Hall plate using CMOS switches and Hall voltage measurement taps, while maintains the Hall voltage signal that is induced by the external magnetic flux. The signal is then captured by a sample-and-hold circuit and further processed using low-offset bipolar circuitry. This technique produces devices that have an extremely stable quiescent Hall output voltage, are immune to thermal stress, and have precise recoverability after temperature cycling. A relatively high sampling frequency is used for faster signal processing capability can be processed.

Magnetic Field Detection Mechanism

The Hall IC cannot detect magnetic fields that run horizontal to the package top layer. Be certain to configure the Hall IC so that the magnetic field is perpendicular to the top layer.

Operation

The output of this device switches low (turns on) when a magnetic field perpendicular to the Hall sensor exceeds the operate point B_{OPS} (or is less than B_{OPN}). After turn-on, the output is capable of sinking up to 1mA and the output voltage is $V_{OUT(ON)}$. When the magnetic field is reduced below the release point B_{RPS} (or increased above B_{RPN}), the device output switches high (turns off). The difference between the magnetic operates and release points are the hysteresis (B_{hys}) of the device. This built-in hysteresis allows clean switching of the output even in the presence of external mechanical vibration and electrical noise.

Applications:

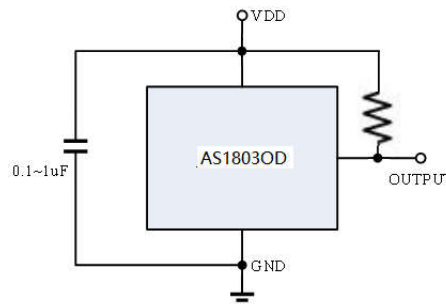

AS1803OD's pole-independent sensing technique allows for operation with either a north or south poles magnet orientation, enhancing the manufacturability of the device. The state-of-the-art technology provides the same output polarity for either pole face.

C1 serves two purposes: minimizing ripples on the input voltage and enhancing immunity from RF transmission noises within close proximity. Recommended values are between 100nF and 1uF. The larger the capacitance, the better the noise immunity is for the AS1803OD.

It is strongly recommended that an external bypass capacitor be connected (in close proximity to the Hall sensor) between the supply and ground of the device to reduce both external noise and noise generated by the chopper-stabilization technique. This is especially true due to the relatively high impedance of battery supplies. The simplest form of magnet that will operate these devices is a bar magnet with either pole near the branded surface of the device.

Thermal Considerations

The maximum IC junction temperature should be restricted to 125°C under normal operating conditions. This restriction limits the power dissipation of the AS1803OD. Calculate the maximum allowable dissipation, $P_{D(max)}$, and keep the actual dissipation less than or equal to $P_{D(max)}$. The maximum-power-dissipation limit is determined using following equation:

$$P_{D(MAX)} = \frac{125^{\circ}\text{C} - T_A}{R_{\theta JA}}$$

Where, T_A is the maximum ambient temperature for the application. $R_{\theta JA}$ is the thermal resistance junction-to-ambient given in Power Dissipation Table.

■ Package Information

SOT23-3L:

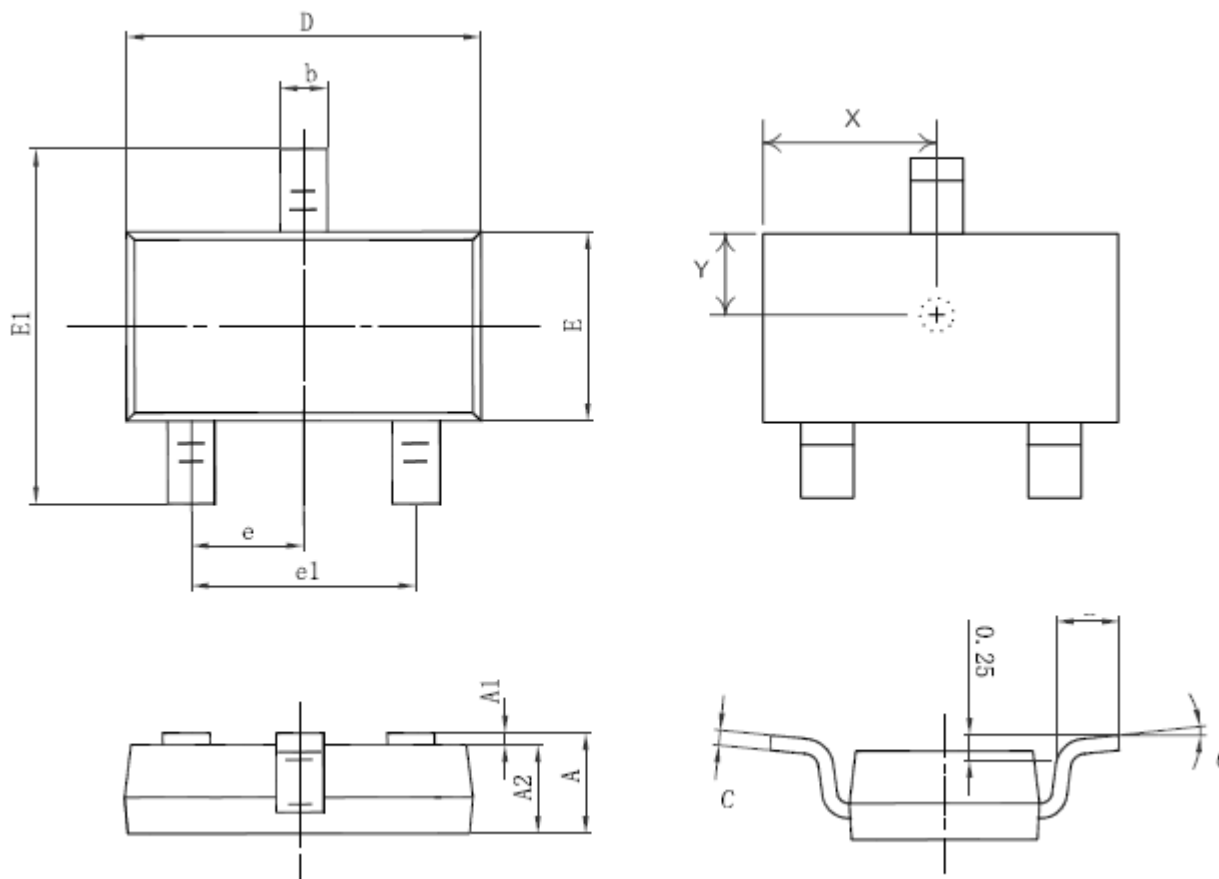

Symbol	Dimensions In Millimeters		Dimensions In Inches	
	Min.	Max.	Min.	Max.
A	1.050	1.250	0.028	0.035
A1	0.000	0.100	0.000	0.004
A2	1.050	1.150	0.028	0.031
b	0.350	0.500	0.014	0.020
c	0.080	0.200	0.003	0.008
D	2.820	3.020	0.111	0.119
E	1.600	1.700	0.063	0.067
E1	2.650	2.950	0.104	0.116
e	0.950(BSC)		0.037(BSC)	
e1	1.900(BSC)		0.075(BSC)	
L	0.300	0.600	0.012	0.024
θ	0°	8°	0°	8°
X	1.410	1.510	0.056	0.059
Y	0.800	0.850	0.031	0.033

SIP-3L:

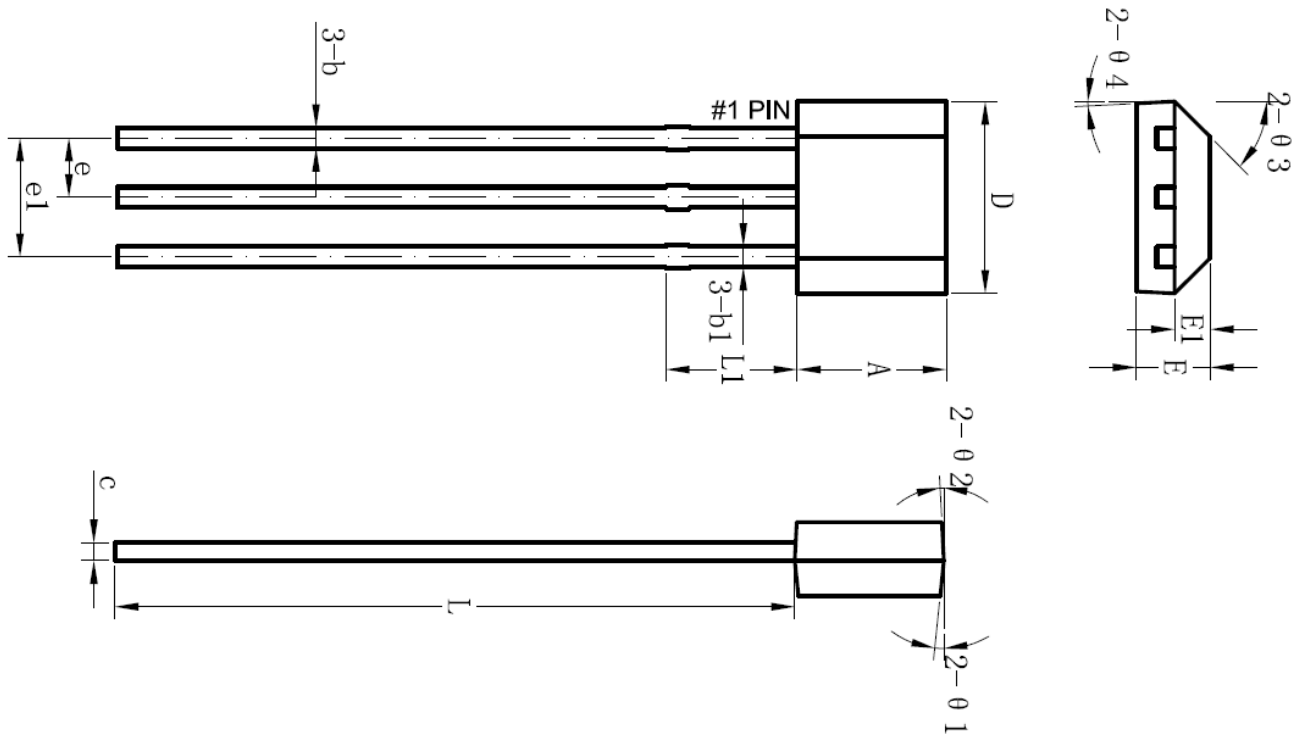

Symbol	Dimensions In Millimeters			Dimensions In Inches		
	Min.	Typ.	Max.	Min.	Typ.	Max.
A	2.900	3.000	3.100	0.114	0.118	0.122
b	0.350	0.390	0.560	0.014	0.015	0.022
b1	-	0.440	-	-	0.017	-
C	0.360	0.380	0.510	0.014	0.015	0.020
D	3.900	4.000	4.100	0.153	0.157	0.161
E	1.420	1.520	1.620	0.056	0.060	0.064
E1	-	0.750	-	-	0.030	-
E	-	1.270	-	-	0.050	-
e1	-	2.540	-	-	0.100	-
L	13.50	14.50	15.50	0.531	0.571	0.610
L1	-	1.600	-	-	0.063	-
θ 1	-	6°	-	-	6°	-
θ 2	-	3°	-	-	3°	-
θ 3	-	45°	-	-	45°	-
θ 4	-	3°	-	-	3°	-

■ Packing Information

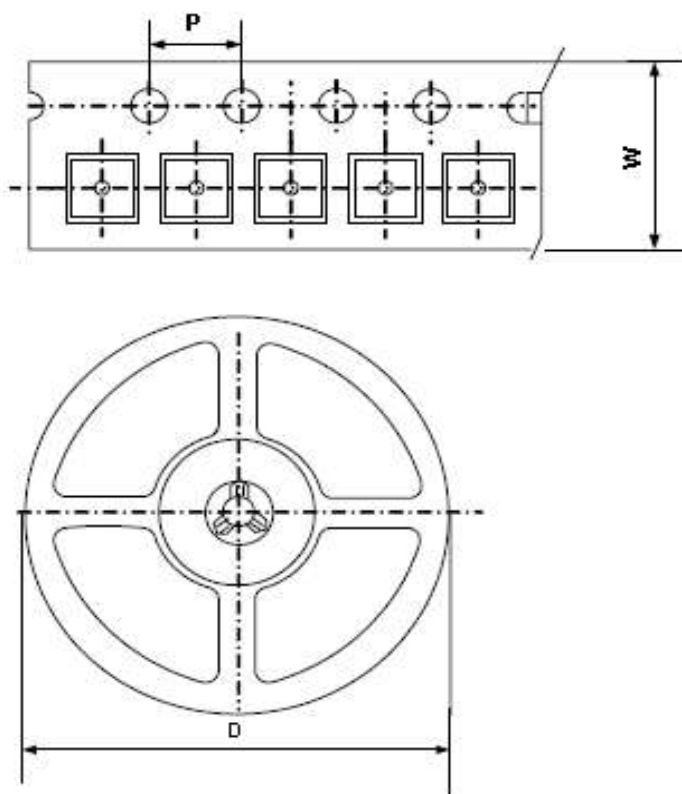

Package Type	Carrier Width(W)	Pitch(P)	Reel Size(D)	Packing Minimum
SOT23-3L	8.0±0.1 mm	4.0±0.1 mm	180±1 mm	3000pcs

Note: Carrier Tape Dimension, Reel Size and Packing Minimum

■ Packing Information

SIP-3L

1. Packing type: Bulk
2. Packing minimum: 1000pcs